

Reciprocating Compressors

Product Overview

Our technologies have been at the forefront of reciprocating compression for more than 100 years

- **1922** First ammonia synthesis compressor
- **1964** First hypercompressor for LDPE
- **1966** First compressors for re-injection of associated gas
- **1976** Highest working pressure in a hypercompressor for LDPE: 3,500 bar
- **1990** Fully balanced compressor for offshore applications
- **2014** Highest installed power for a LDPE compression unit: +38 MW
- **2019** One of the largest API 618 compressors: 20+ MW for 8-cylinder unit

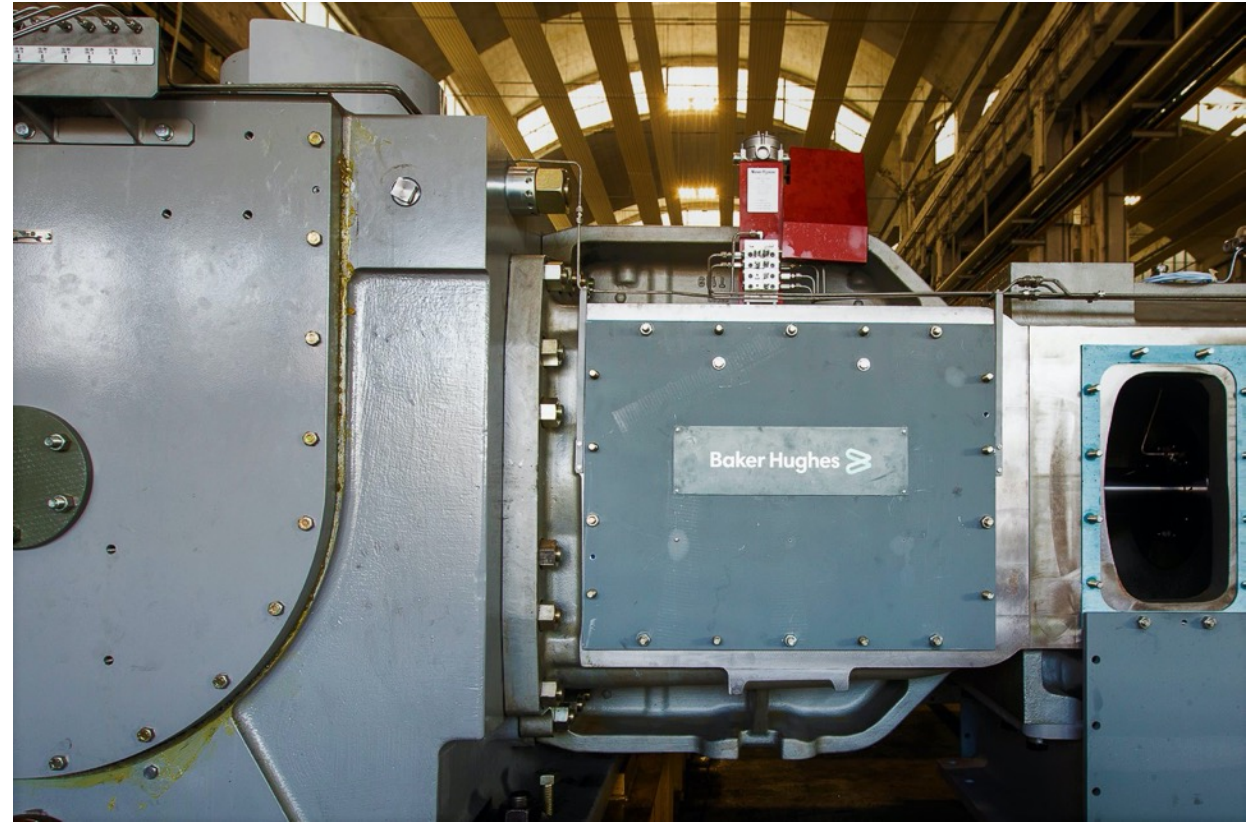

Serving multiple markets

Refinery

- Hydrocracking
- Hydrotreating
- Hydrodesulphurization
- Reforming
- Other hydrogen services

Chem/petrochemical

- Refrigeration
- Ethylene, HDPE, LLDPE
- Ethylene oxide
- Polypropylene
- Low-density polyethylene

Natural gas

- Re-injection
- Gas lift
- Gathering
- Pipeline
- Storage

Product line at a glance

API 618 slow speed

Process-gas compressors

- Balanced opposed type
- Horizontal and opposed cylinders
- Cylinders: 1 to 10
- Speed (rpm): 300 to 750
- Pistons speed (m/s): 3 to 4.5

API 618 high speed

Natural gas compressors

- Balanced opposed type
- Speed (rpm): 750 to 1,200
- Pistons speed (m/s): 5 to 6
- Common in offshore and FPSO because of their reduced footprint vs. equivalent slow-speed unit

Hypercompressors

High-power machines for LDPE production up to 3,500 bar

- Unique frame design
- Suction pressure: 200 to 300 bar
- Discharge Pressure: 1,200 to 3,500 bar
- Installed power up to 40 MW

Reciprocating compressor portfolio

Family	Frame size Model	Throws (#)	Max. power * (kW)	Max. rod load (kN)	Max. speed (rpm)
API 618 process	OA	1	435	117	800
API 618 process	HA	2-4	2,120	145	1,000
API 618 process	HB	2-6	5,520	236	800
API 618 process	HD	2-8	10,400	322	700
API 618 process	HE	2-10	28,700	670	800
API 618 process	HF	2-10	34,600	1,140	514
API 618 process	HG	2-10	66,820	1,980	514
API 618 natural gas	SHM	2-6	7,980	358	1,200
API 618 natural gas	SHMB	2-4	5,320	358	1,200
LDPE	PH	4-24 **	36,000	1,450	310
LDPE	PK	4-24 **	72,000	2,900	310

* At max. speed and max. number of cylinders.

** Number of cylinders. Up to 12 cylinders in a single frame.

API 618 reciprocating compressor

Main components

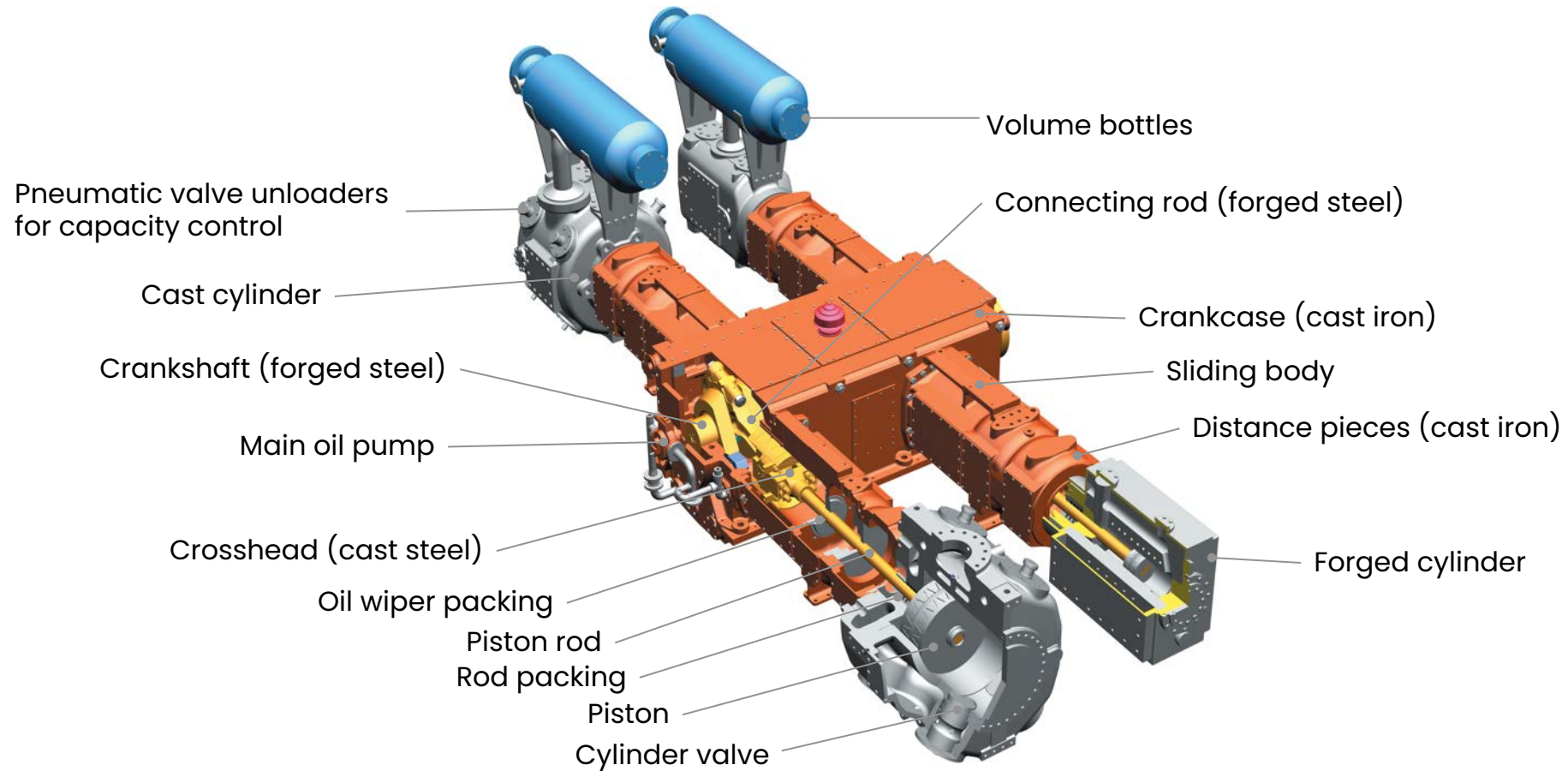

Low density polyethylene (LDPE)

A challenging reciprocating compressor application

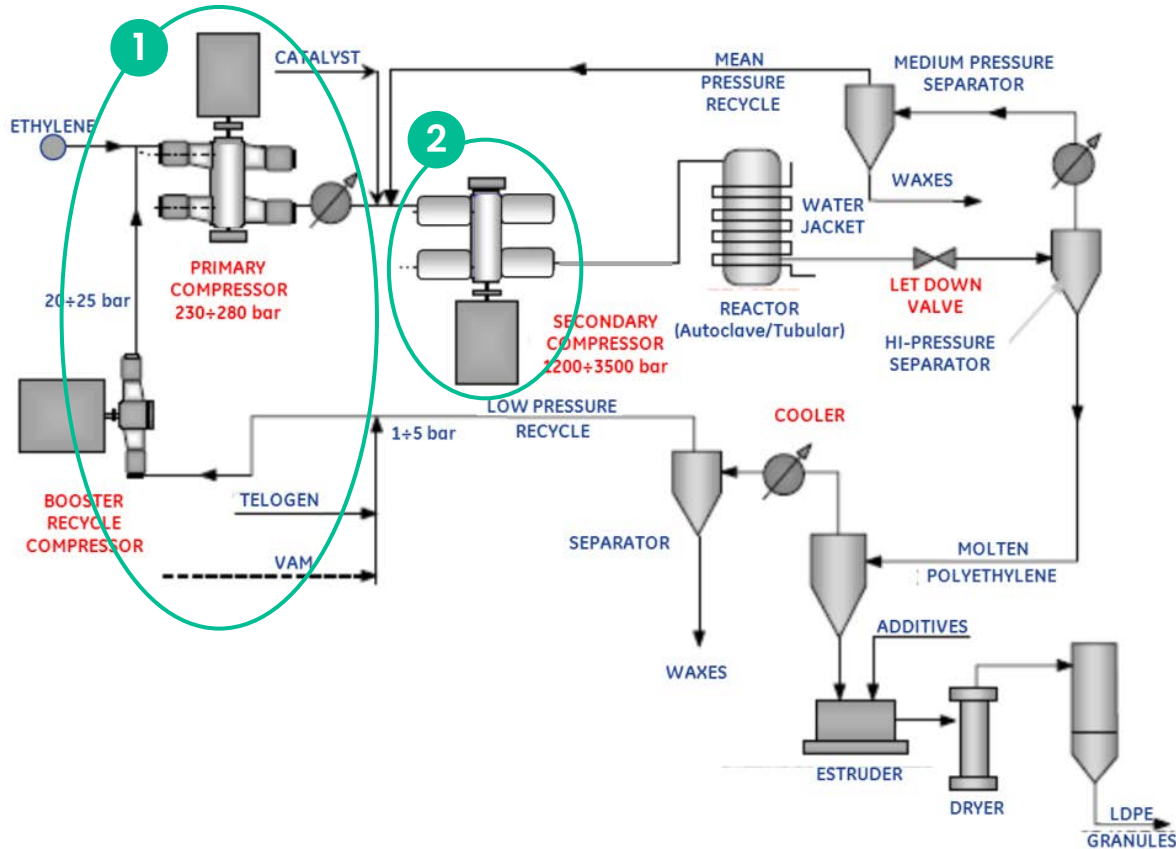

Booster/primary compressor

- Two services on single frame
- 2 to 3 stages on booster, and 2 to 3 stages on primary
- 6 or 8-cylinder configuration
- Suction pressure: 1 to 2 bar
- Discharge pressure: 300 bar
- Installed power up to 12 MW
- Scope of supply includes process gas plant—vessels, separators, gas coolers, and control/safety valves



Hypercompressor

- 2-stage service
- Suction pressure: 200 to 300 bar
- Discharge pressure: 1,200 to 3,500bar
- Installed power up to 40 MW
- Industry biggest installed hyper is a 20PK, 20 cylinders, twin frame with 33 MW installed power

Hypercompressor for LDPE

Main components

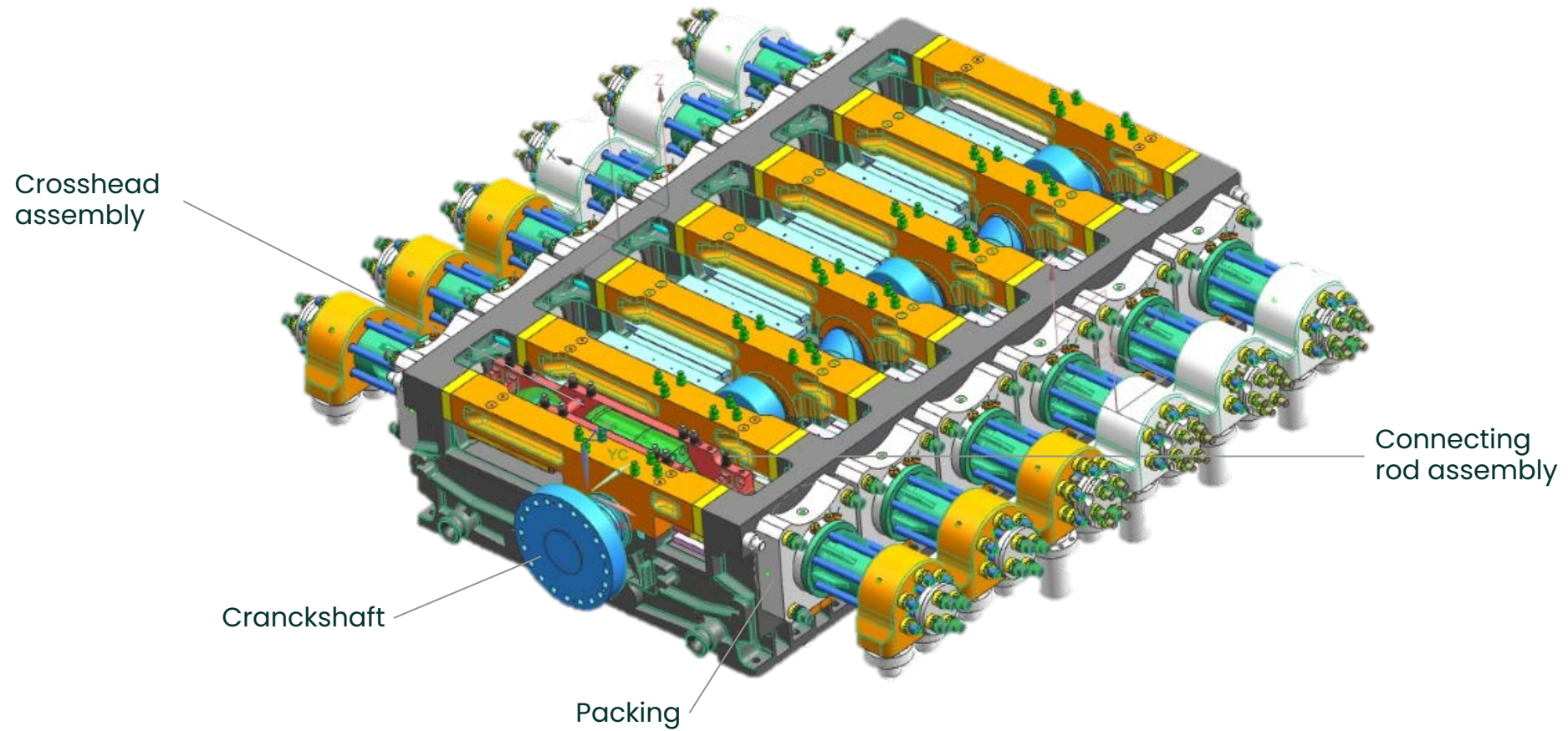

Acoustic and dynamic piping analysis

- Baker Hughes–Nuovo Pignone started acoustic analysis in the mid-1960s with an analogue simulator
- Unique in-house team expertise
- Extensive experience: more than 1,000 plants analyzed
- Always performed in conjunction with mechanical analysis
- Proprietary digital program in use since 1989, tuned with our analog simulator and field test, validated with over 25 years of experience

Expertise, modern tools, and facilities to define the optimum configuration for any type of reciprocating compressor plant—including the most critical as LDPE plants

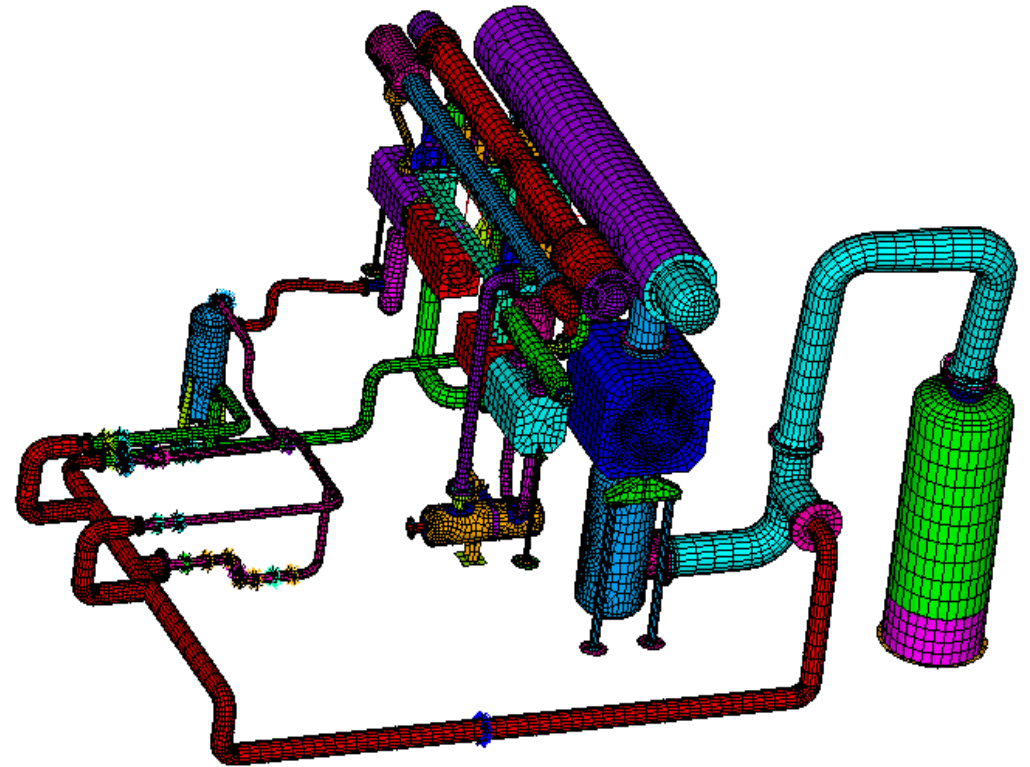

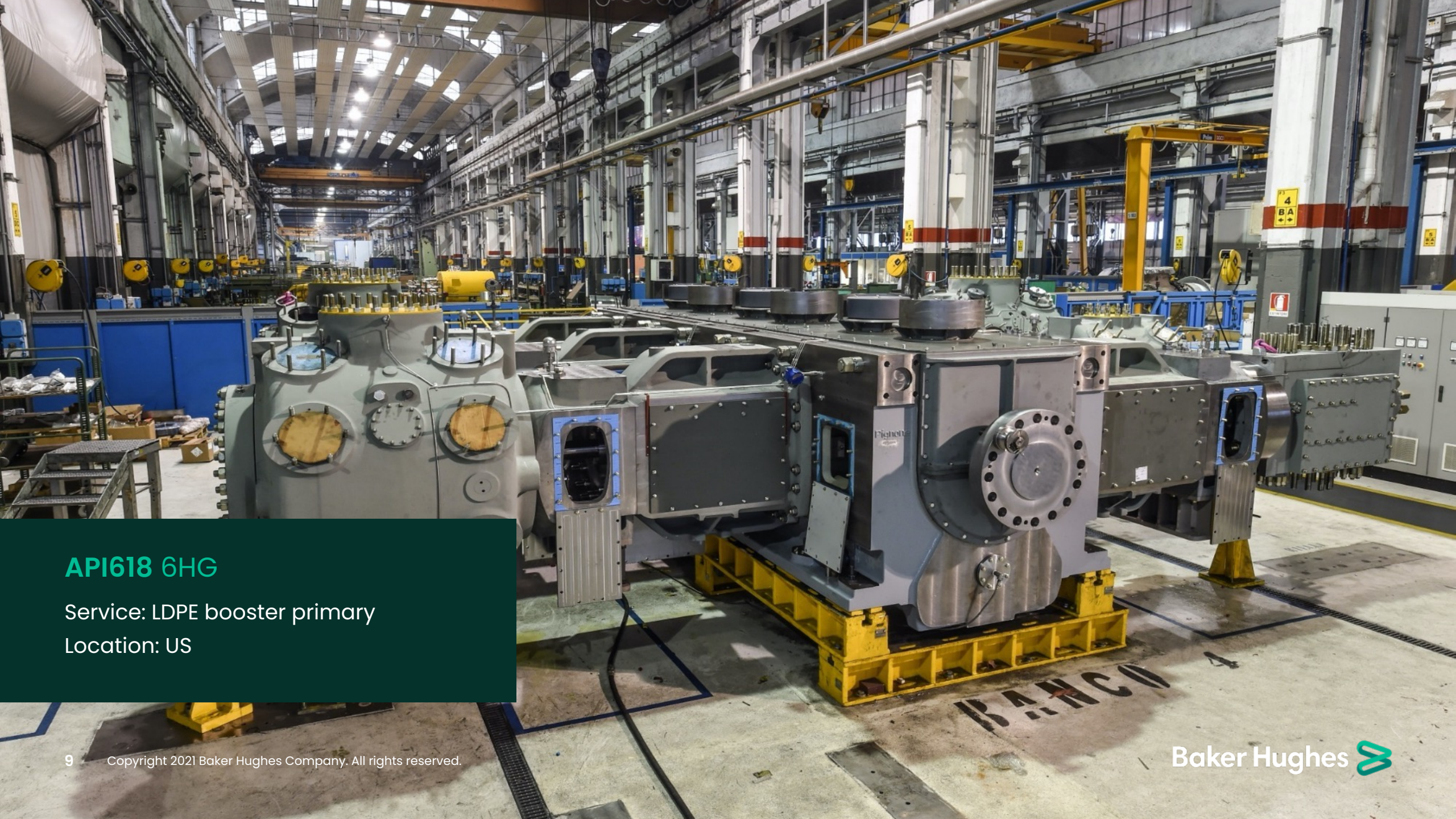

API618 6HG

Service: LDPE booster primary

Location: US

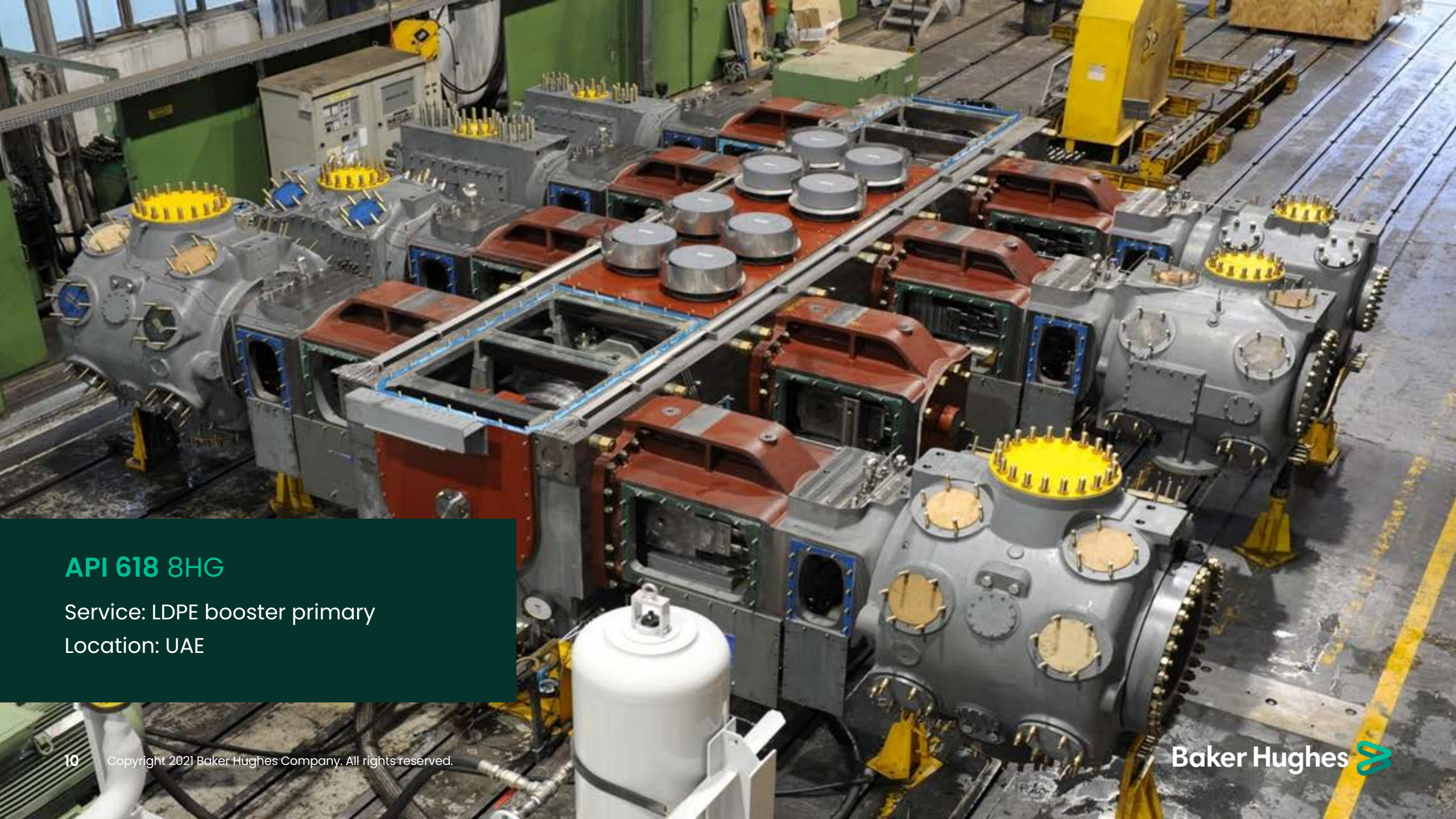

API 618 8HG

Service: LDPE booster primary

Location: UAE



API618 6HE + LDPE 8PK

Service: LDPE plant

Location: China

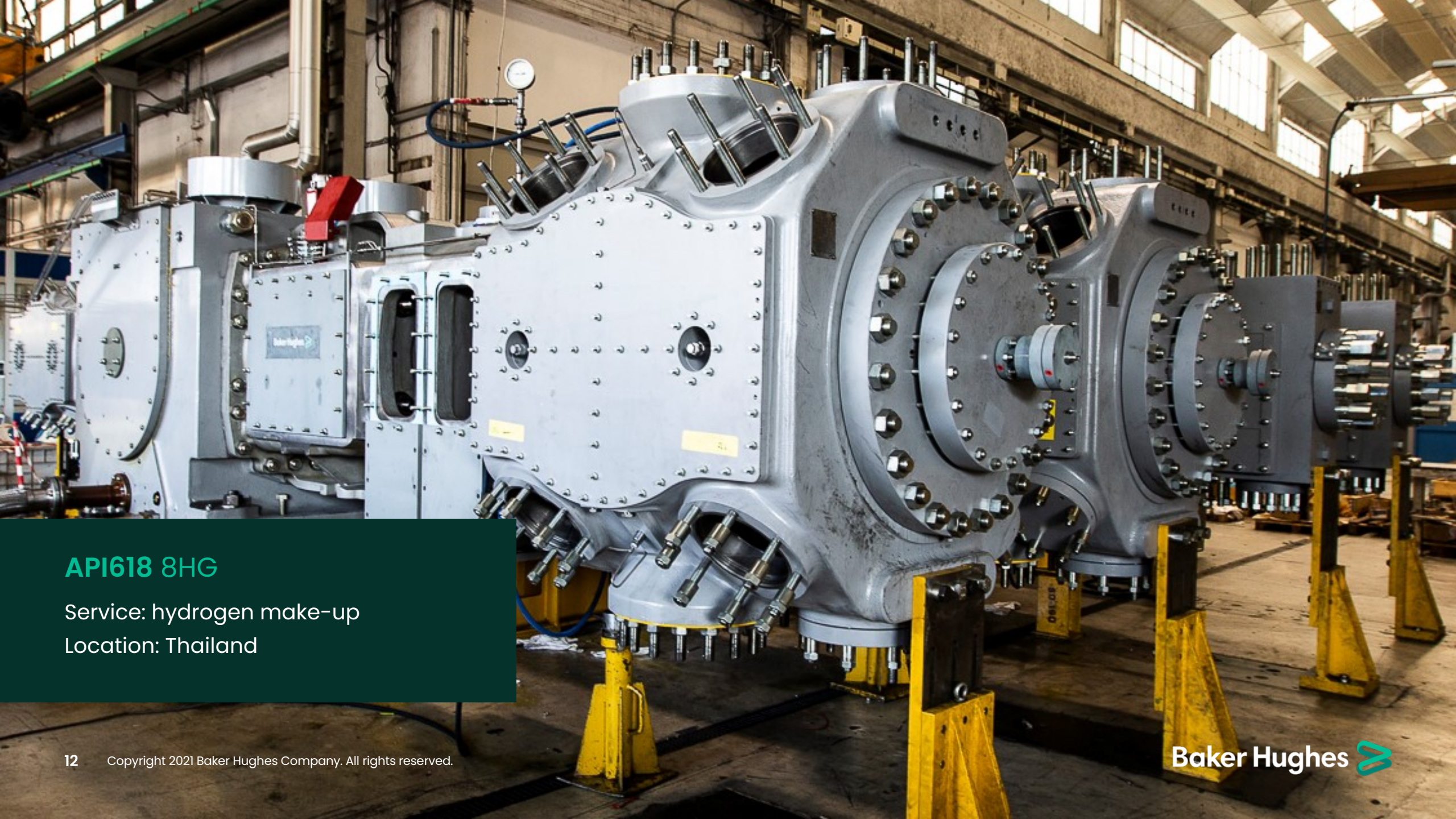

API618 8HG

Service: hydrogen make-up

Location: Thailand



API618 8HG

Service: hydrogen make-up

Location: Kuwait

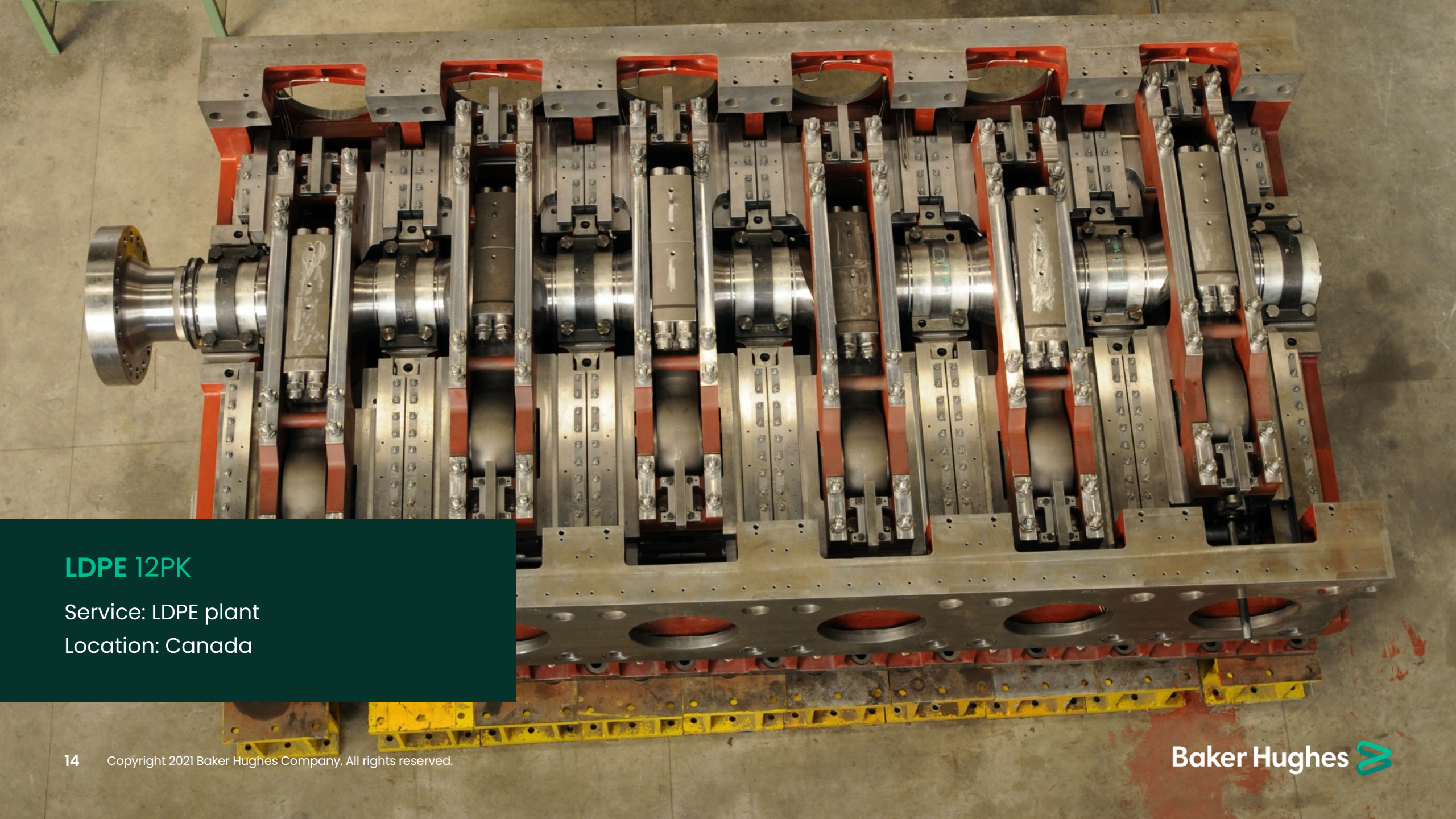

LDPE 12PK

Service: LDPE plant

Location: Canada

bakerhughes.com/reciprocating-compressors

API 618 process compressors

<https://youtu.be/pV32BlgMGvA>

LDPE compressors

<https://youtu.be/4qKvF6cEpKk>



Baker Hughes 